

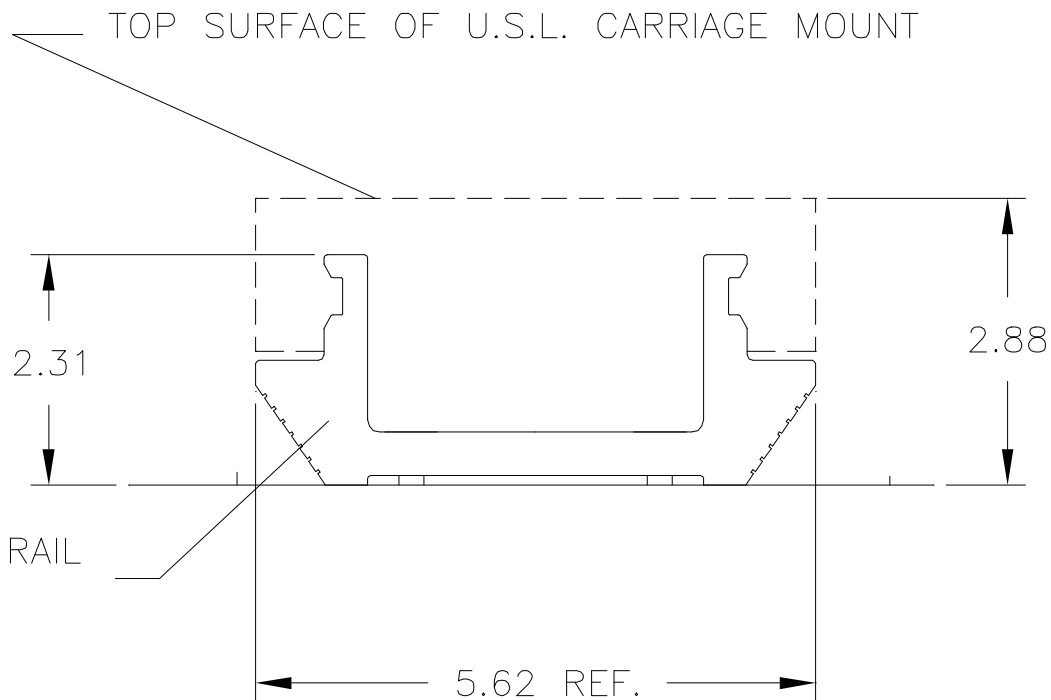

EXCEPT AS MAY BE OTHERWISE PROVIDED BY CONTRACT, THESE DRAWINGS AND SPECIFICATIONS ARE THE PROPERTY OF U.S. LASER CORP., ARE ISSUED IN STRICT CONFIDENCE AND SHALL NOT BE REPRODUCED, COPIED, OR USED AS THE BASIS FOR THE MANUFACTURE OR SALE OF APPARATUS WITHOUT PERMISSION. ALL COMMON LAW, COPYRIGHT AND PROPRIETARY INFORMATION RIGHTS ARE RETAINED BY U.S. LASER CORP.

REVISIONS			
REV	DESCRIPTION	DATE	APPROVED



		REMOVE ALL BURRS AND BREAK SHARP EDGES .010 MAX	UNLESS OTHERWISE SPECIFIED DIMENSIONS ARE IN INCHES	S.O. NO.		 825 WINDHAM COURT NORTH, WYCKOFF, NEW JERSEY 07481			
		MATERIAL		TOLERANCES: 3 PLACE DECIMALS ±.005 2 PLACE DECIMALS ±.01 FRACTIONS ±1/64 ANGLES ±1°	DRAWN J. JORGE				
		FINISH		CHECKED		SIZE A	CAGE CODE OBMT7	DRWG NO. 512065	REV
NEXT ASSY	USED ON			ENGINEER		SCALE: HALF		SHEET 1 OF 1	
APPLICATION				APPROVED					